

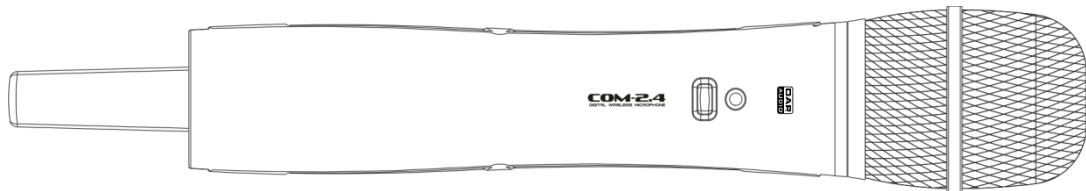

MANUAL

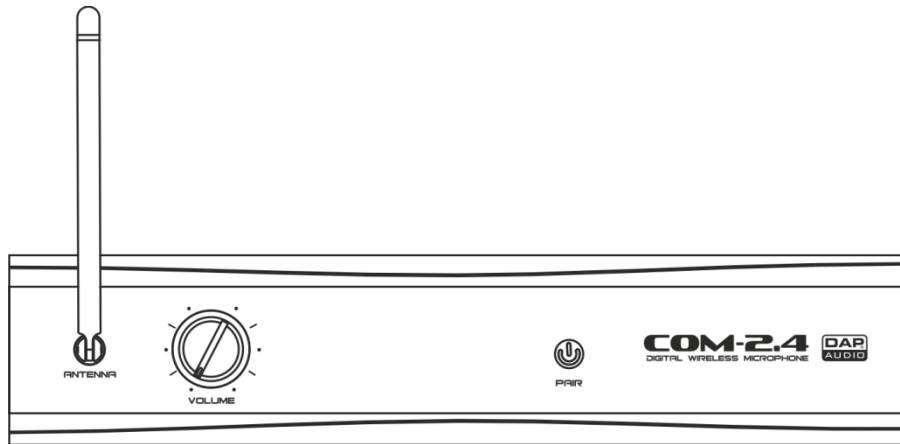

ENGLISH

COM-2.4

V1

Ordercode: D1410

Table of contents

Warning	2
Unpacking Instructions.....	2
Safety Instructions	2
Operating Determinations	3
Return Procedure.....	3
Claims.....	4
Description of the device	4
Features	4
Overview	4
Set Up and Operation	5
Receiver installation	5
Receiver controls and functions	6
Front Panel Controls and Functions.	6
Rear Panel.....	7
Controls and Functions.....	7
COM-2.4 transmitter battery selection and installation.	8
Pairing Instructions	8
Specifications	9
Notes	10

Warning



**FOR YOUR OWN SAFETY, PLEASE READ THIS USER MANUAL CAREFULLY
BEFORE YOUR INITIAL START-UP!**



Unpacking Instructions

Immediately upon receiving this product, carefully unpack the carton and check the contents to ensure that all parts are present and have been received in good condition. Notify the dealer immediately and retain packing material for inspection if any parts appear damaged from shipping or the carton itself shows signs of mishandling. Save the carton and all packing materials. In the event that a fixture must be returned to the factory, it is important that the fixture be returned in the original factory box and packing.

Your shipment includes:

- Wireless Microphone COM-2.4
- Receiver DW24R
- AC Power Adapter
- Jack – Jack Unbalanced cable 1,65m



CAUTION!
Keep this device away from rain and moisture!
Unplug mains lead before opening the housing!



Safety Instructions

Every person involved with the installation, operation and maintenance of this device have to:

- be qualified
- follow the instructions of this manual



CAUTION! Be careful with your operations.
With a dangerous voltage you can suffer
a dangerous electric shock when touching the wires!



Before your initial start-up, please make sure that there is no damage caused by transportation. Should there be any, consult your dealer and do not use the device.

To maintain perfect condition and to ensure a safe operation, it is absolutely necessary for the user to follow the safety instructions and warning notes written in this manual.

Please consider that damages caused by manual modifications to the device are not subject to warranty. This device contains no user-serviceable parts. Refer servicing to qualified technicians only.

IMPORTANT!

The manufacturer will not accept liability for any resulting damages caused by the non-observance of this manual or any unauthorized modification to the system.

- Never let the power-cord come into contact with other cables! Handle the power-cord and all connections with the mains with particular caution!
- Never remove warning or informative labels from the unit.
- Never use anything to cover the ground contact.

- Never leave any cables lying around.
- Do not open the device and do not modify the device.
- Do not insert objects into air vents.
- Do not connect this device to a dimmer pack.
- Do not switch the system on and off in short intervals, as this would reduce the system's life.
- Only use device indoor, avoid contact with water or other liquids.
- Avoid flames and do not put close to flammable liquids or gases.
- Always disconnect AC adapter from the mains, when device is not used or before cleaning! Only handle the AC adapter by the plug. Never pull out the AC adapter by tugging the power-cord.
- Make sure you don't use the wrong kind of cables or defective cables.
- Make sure that the available voltage is not higher than stated on the rear panel.
- Make sure that the power-cord is never crimped or damaged. Check the system and the power-cord from time to time.
- If system is dropped or struck, disconnect mains power supply immediately. Have a qualified engineer inspect for safety before operating.
- If the system has been exposed to drastic temperature fluctuation (e.g. after transportation), do not switch it on immediately. The arising condensation water might damage your system. Leave the system switched off until it has reached room temperature.
- If your Dap Audio device fails to work properly, discontinue use immediately. Pack the unit securely (preferably in the original packing material) and return it to your Dap Audio dealer for service.
- Repairs, servicing and electric connection must be carried out by a qualified technician.
- For replacement use fuses of same type and rating only.
- WARRANTY: Till one year after date of purchase.

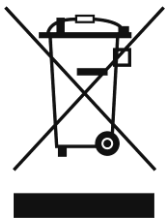

Disposing of this product should not be placed in municipal waste and should be separate collection.

Operating Determinations

If this system is operated in any other way, than the one described in this manual, the product may suffer damages and the warranty becomes void.

Any other operation may lead to dangers like short-circuit, burns, electric shock, etc.



Return Procedure



Returned merchandise must be sent prepaid and in the original packing, call tags will not be issued. Package must be clearly labeled with a Return Authorization Number (RMA number). Products returned without an RMA number will be refused. Highlite will not accept the returned goods or any responsibility. Call Highlite 0031-455667723 or mail offersales@highlite.nl and request an RMA prior to shipping the fixture. Be prepared to provide the model number, serial number and a brief description of the cause for the return. Be sure to properly pack fixture, any shipping damage resulting from inadequate packaging is the customer's responsibility. Highlite reserves the right to use its own discretion to repair or replace product(s). As a suggestion, proper UPS packing or double-boxing is always a safe method to use.

Note: If you are given an RMA number, please include the following information on a piece of paper inside the box:

- 1) Your name
- 2) Your address
- 3) Your phone number
- 4) A brief description of the symptoms

Claims

The client has the obligation to check the delivered goods immediately upon delivery for any shortcomings and/or visible defects, or perform this check after our announcement that the goods are at their disposal. Damage incurred in shipping is the responsibility of the shipper; therefore the damage must be reported to the carrier upon receipt of merchandise. It is the customer's responsibility to notify and submit claims with the shipper in the event that a fixture is damaged due to shipping. Transportation damage has to be reported to us within one day after receipt of the delivery. Any return shipment has to be made post-paid at all times. Return shipments must be accompanied with a letter defining the reason for return shipment. Non-prepaid return shipments will be refused, unless otherwise agreed in writing. Complaints against us must be made known in writing or by fax within 10 working days after receipt of the invoice. After this period complaints will not be handled anymore. Complaints will only then be considered if the client has so far complied with all parts of the agreement, regardless of the agreement of which the obligation is resulting.

Description of the device

Features

- Operating Band: ISM 2.4 GHz free band.
- GFSK digital modulation / demodulation.
- Intelligent Frequency Hopping.
- Automatic mute in bad channel quality or high error code rate.
- Memorize matched devices.
- One receiver can match with several transmitters, though only one transmitter can be used at once.
- More than 25 meters transmit distance in open place.
- Power / pairing status indicator.
- Low-cost design.

Overview

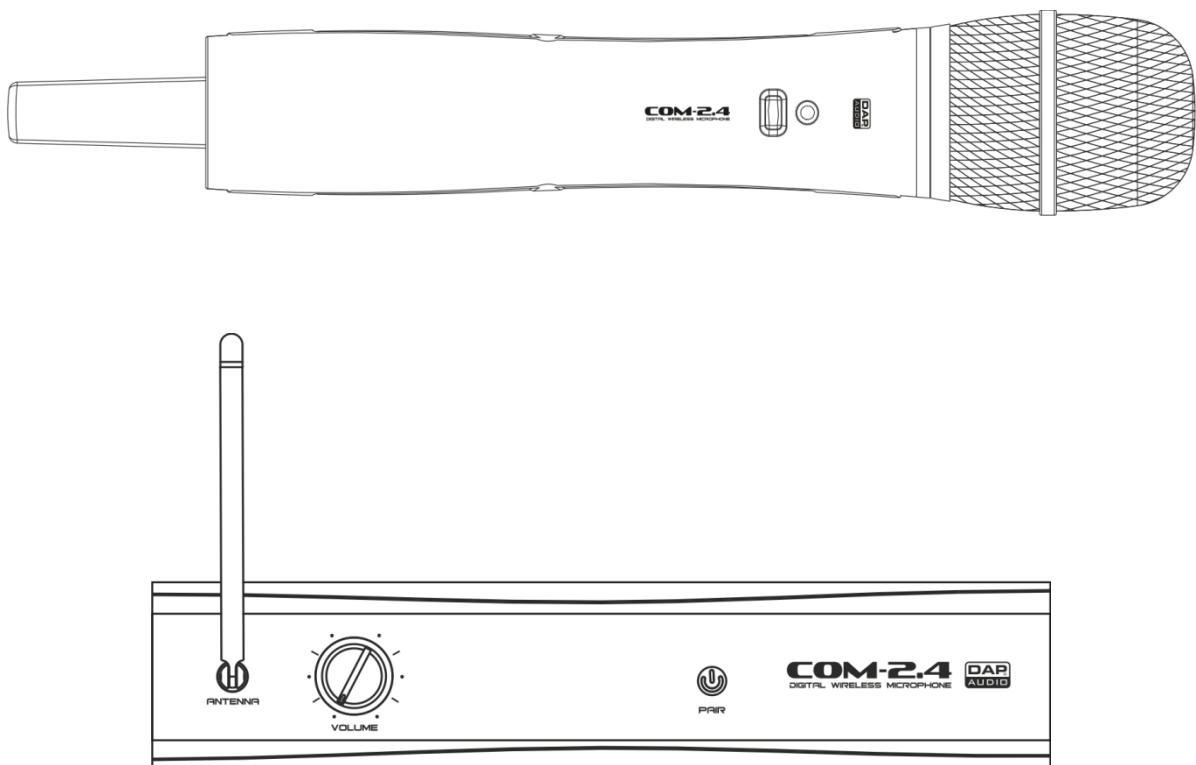

Set Up and Operation

Receiver installation

Location

For best operation the receiver should be at least 1 meter above the ground and at least 1 meter away from a wall or metal surface to minimize reflections. Keep the receiver antenna away from noise sources such as other digital equipment, microwave ovens, as well as large metal objects. Keep COM-2.4 receiver 9 meters away from wireless access points .

Output Connection

There is one audio output on the rear panel: unbalanced 1/4" TRS phone jack. Use a shielded audio cable to connect the receiver and the mixer.

Power Connection

Connect the supplied power adapter to the DC power input on the back of the receiver. Make sure the plug can't be disconnected by an accidental tug on the cord.

The receiver has no power Off / On switch. The receiver will be energized whenever the power adapter is connected and plugged into the AC outlet. Unplug the power supply from the AC outlet when the system is not in use, both for safety and conserving energy.

Antenna

Rotate the permanently attached antenna vertically to get the best reception .

Receiver controls and functions

Front Panel Controls and Functions.

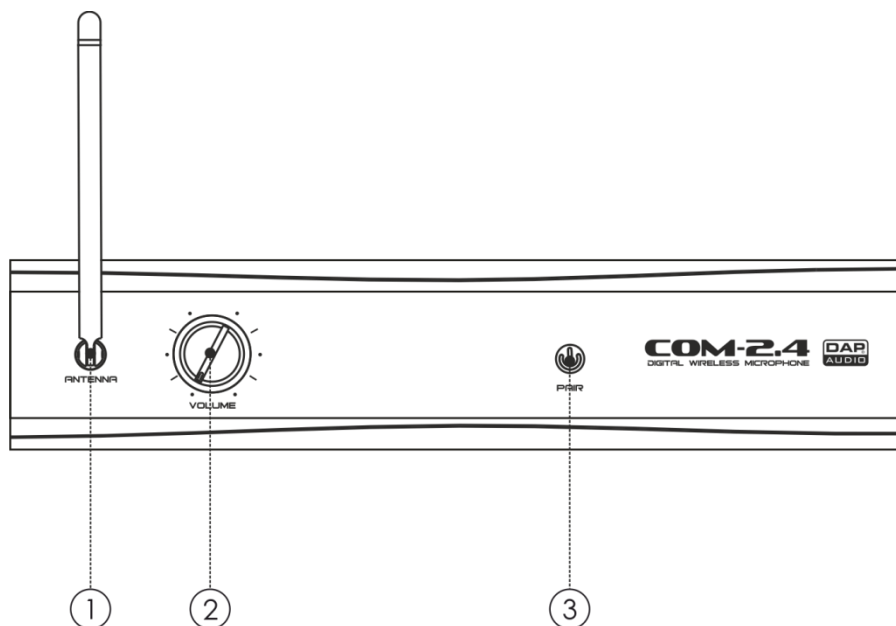

- ① Antenna: Position the antenna vertically

Volume knob

- ②
- Adjust the volume
 - Indicate pairing status:

on =	connected with COM-2.4 transmitter
off =	not connected with any device
blinking =	in pairing status

Pair button

- ③
- Indicate the receiver is on by lightening
 - Press and hold for about 5 seconds to enter in pairing status.

NOTE: Turn down the volume when the receiver is in pairing mode.
An audio pulse is generated on the output of the receiver!

Rear Panel.

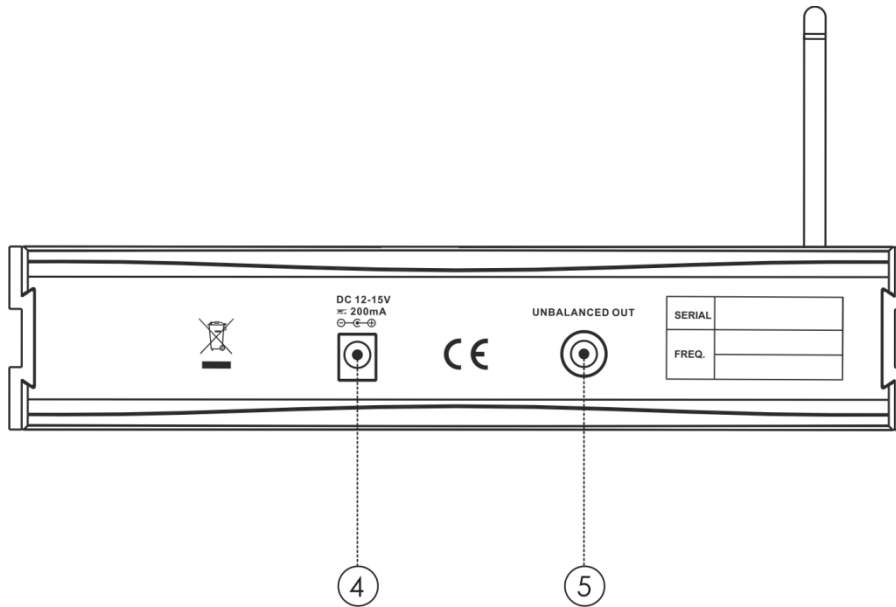

- ④ Power input jack: Connect the DC plug with the supplied in-line AC adapter
- ⑤ Unbalanced 1/4" TRS phone audio output jack

Controls and Functions.

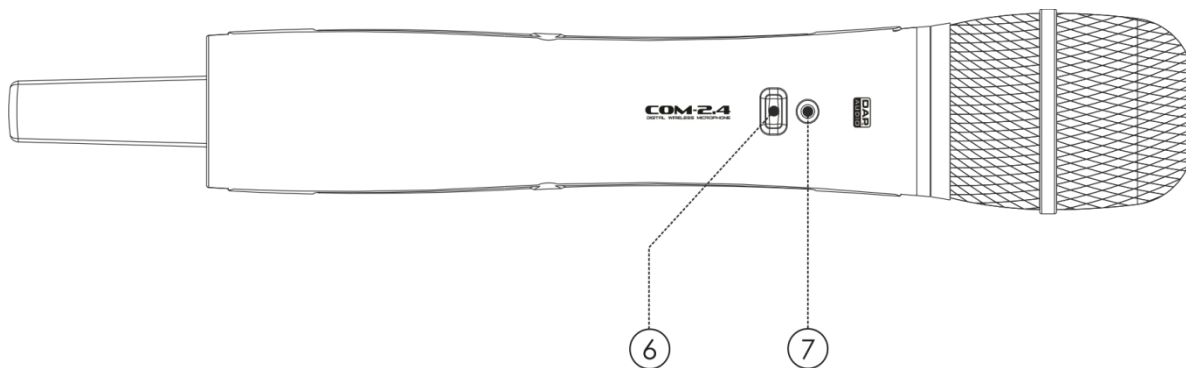

- Power/Pair button
- ⑥
 - Power on/off the COM-2.4 by pressing and holding it for about 0.5 seconds
 - Pair the transmitter and receiver by pressing and holding it for about 5 seconds
- LED indicator:
- ⑦

on =	the COM-2.4 is on or/ and in pair
off =	the COM-2.4 is off
Blinking =	in pairing status or short of power

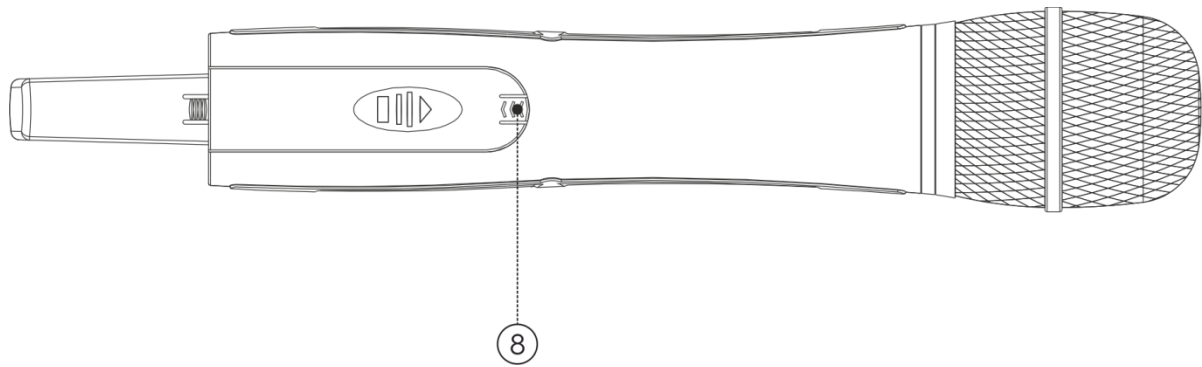
COM-2.4 transmitter battery selection and installation.

Two alkaline AA batteries are recommended. When inserting the batteries, observe the correct polarity as marked inside the battery compartment. When the LED is blinking (and the mic is not in pairing mode) please replace the batteries.

Press (8) and slide out the battery cover. Carefully insert two fresh AA alkaline batteries as the polarity marks indicates. Place the battery cover and slide it in.

Pairing Instructions

Power on the COM-2.4 receiver and COM-2.4 handheld digital wireless, press and hold the pair button simultaneous for about 5 seconds The LED of the COM-2.4 and the volume circle of the COM-2.4 will blink to show they are in pairing status. After the pairing is successful both indicators will light constantly.

Because the system can memorize the pairing devices, once you have paired them together, you can use them without re-pairing until you have exit the pairing. Though one COM-2.4 receiver can pair with lots of COM-2.4's, only one transmitter can be used at once.

Specifications

COM-2.4 Receiver

Frequency	2.404 - 2.476GHz
RF Sensitivity	-78dBm
Transmission Distance	> 25m (distance insight)
Frequency Response	50Hz - 18KHz (16bit - 38.4KHz)
Distortion	0.05@1KHz
SNR	>89dB
Transmission Delay	18ms
Power Supply	DC12V=200mA

COM-2.4 Transmitter

Carrier Frequency	2.404 - 2.476GHz
Transmitting Power	10dBm MAXERP (Effective Radiated Power)
Transmission Distance	> 25m (distance in sight)
Frequency Response	50Hz - 18KHz (16bit - 38.4KHz)
Distortion	0.05@1KHz
SNR	>89dB
Transmission Delay	18ms
Power Supply	AA*2
Battery Life	> 20 hours



©2013 DAP Audio