

# EPOS

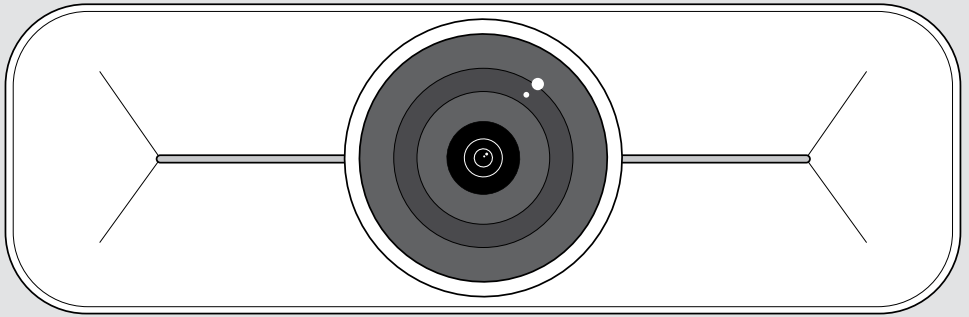

## EXPAND Vision 1M

USB camera for up to mid-sized rooms

User Guide

Model: DSWD3

# Contents

Package contents .....	2
EXPAND Vision 1M at a glance.....	3
How to mount the EXPAND Vision 1M .....	4
How to connect and set up .....	6
Overview of the connections.....	6
Connecting the EXPAND Vision 1M.....	7
Using an optional Kensington® lock .....	8
Installing EPOS Connect.....	8
How to use – the basics.....	9
Adjusting the camera.....	9
Joining meetings / calls.....	10
Good to know.....	11
Changing the camera's pick-up zone.....	11
Fine-tuning the camera's image.....	11
Using the privacy shutter.....	12
How to care for your EXPAND Vision 1M.....	13
Cleaning the product.....	13
Updating the firmware.....	14
If a problem occurs.....	15



For safety instructions, consult the Safety Guide.



For specifications, consult the Fact sheet available at [eposaudio.com](http://eposaudio.com)

## Trademarks

USB Type-C® and USB-C® are trademarks of USB Implementers Forum.

All other trademarks are the property of their respective owners.

# Package contents

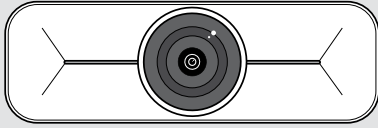

**EXPAND Vision 1M**  
USB camera

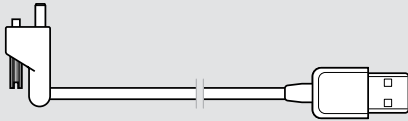

**USB cable, 3 m**  
with USB-C® to USB-A connector  
and affixing screw

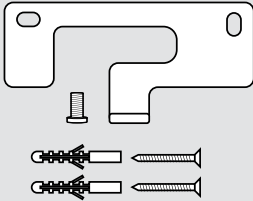

**Wall mount accessories**  
Mounting plate  
Affixing screw  
Dowels\*  
Dowel screws  
\*Differing wall types may require specific dowels

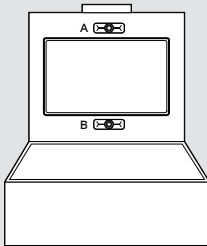

**Quick Guide**  
printed inside the box



**Safety Guide**  
**Compliance sheet**

# EXPAND Vision 1M at a glance

FRONT



Privacy shutter button

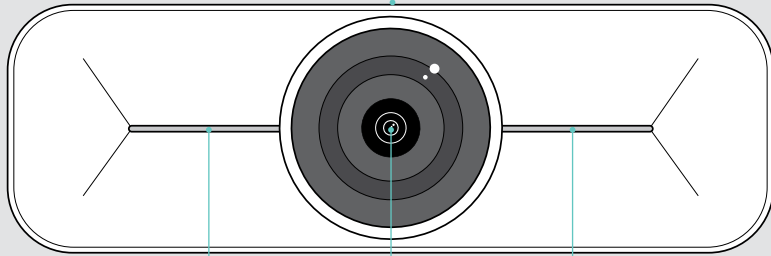

LED

Camera lens

LED

REAR

Kensington socket

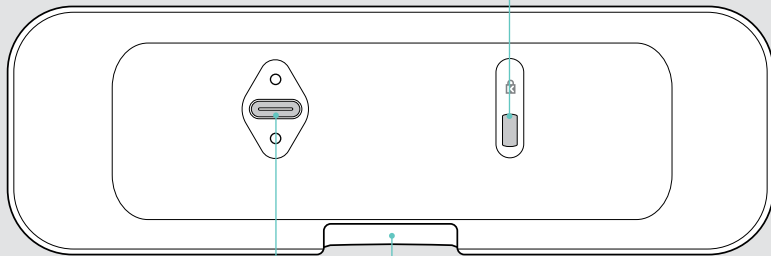

USB-C port with connector locks

Wall mount support

# How to mount the EXPAND Vision 1M



## CAUTION

Danger of accidents or damages!

Drilling into e.g. cables and can lead to accidents.

> Check whether there are any cables or pipes in the wall.

You can mount the USB camera on a wall either **A** on top of or **B** below a TV.

> Choose a position so that the camera meets the eye-height of meeting participants.

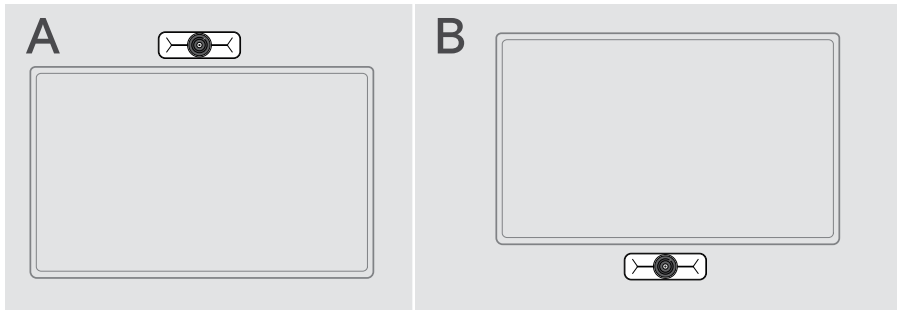

The wall type is an example - other wall types may require different mounting.

- 1 Hold the mounting plate against the wall, balance it and add two marks.
- 2 Drill two holes.
- 3 Insert the two dowels.

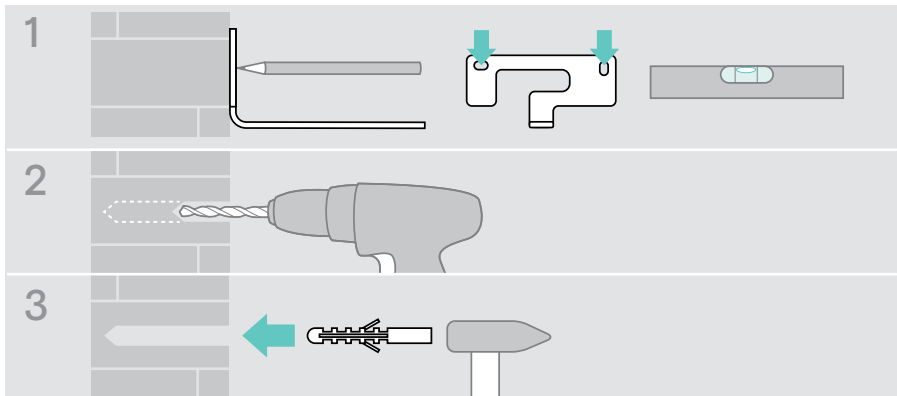

- 4 Hold the mounting plate against the wall and fix it with the screws. Start on the left and bring it in balance with the other screw.
- 5 Hold the camera and connect the required cables as the space is small when finally mounted (see page 7 + page 8 for optional Kensington lock).
- 6 Position the camera and tighten the affixing screw.

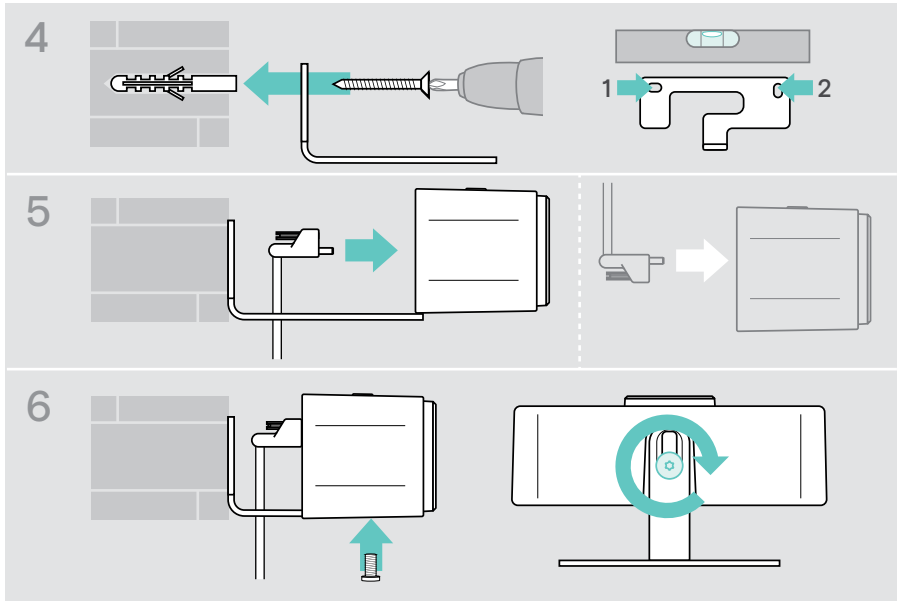

**i** You can rotate the camera a bit to the left- or right-hand side (see page 9).

# How to connect and set up

## Overview of the connections

To get a full system for your EXPAND Vision 1M, you need to connect a TV and a **speakerphone** (e.g. EPOS EXPAND 80).

Besides you need to connect these devices to a network like the below examples:

- **A** Hub / Dock with e.g. a laptop or
  - **B** A part of a meeting room solution (incl. a **Compute box**)
- > Follow the instructions in the next chapters and the corresponding User Guides of your connected devices.

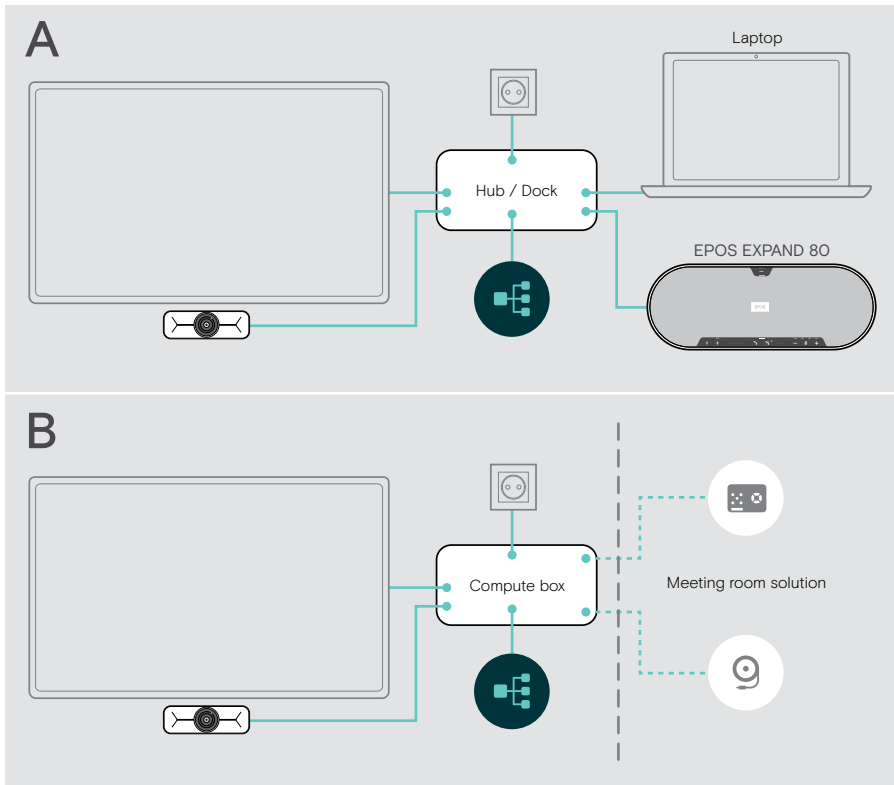

## Connecting the EXPAND Vision 1M

- > Connect the delivered USB cable to the camera and a USB-A socket of your Hub / Dock or Compute box.
- > Tighten the USB-C plug's affixing screw.

The EXPAND Vision 1M turns on automatically as soon as it is powered via the Hub / Dock (connected to a laptop) or Compute box. The LEDs light up white shortly and change to dimmed white for standby mode.

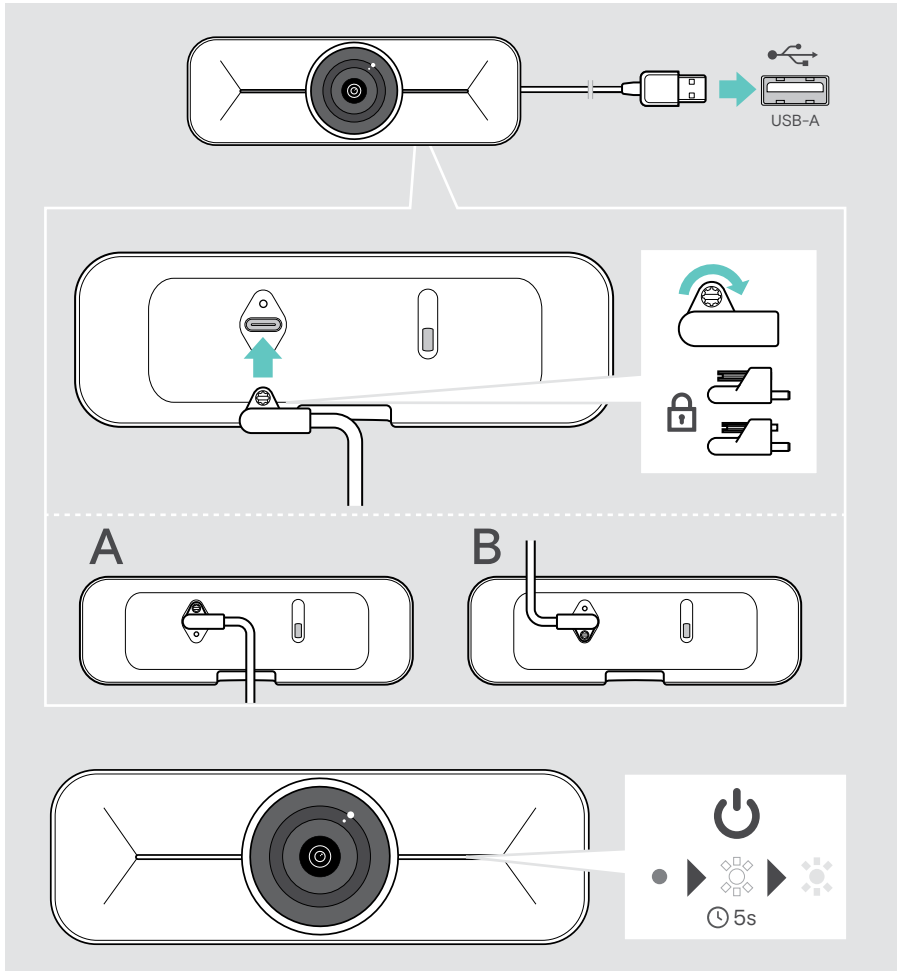



## Using an optional Kensington® lock

You can secure your camera in addition with an optional Kensington lock:

- > Follow the instructions for your Kensington lock to fix it.

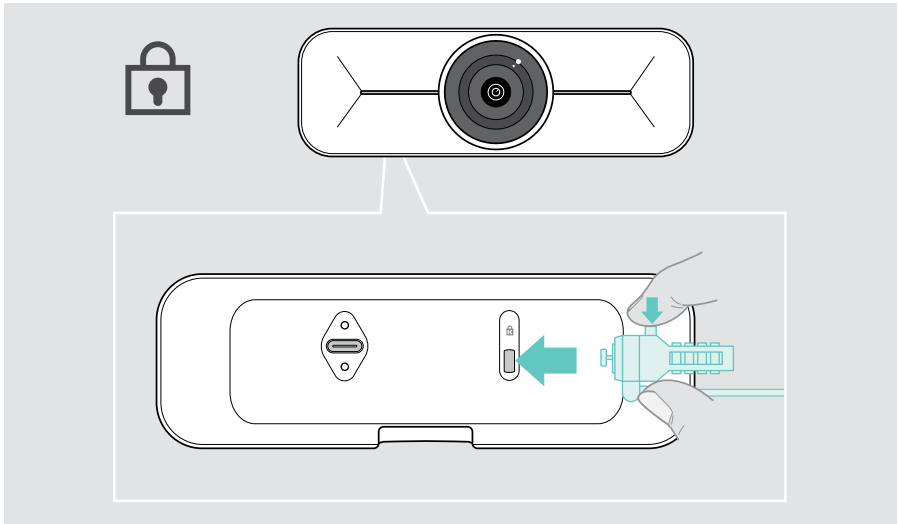

## Installing EPOS Connect

You can change the camera settings and update the firmware via EPOS Connect.

- 1 Download the free [EPOS Connect](https://epos.link/connect) software from [epos.link/connect](https://epos.link/connect).
- 2 Install the software. You need administrator rights on your computer – if necessary, contact your IT department.
- 3 Start EPOS Connect. If there is a new firmware available, the software will guide you through the update process.

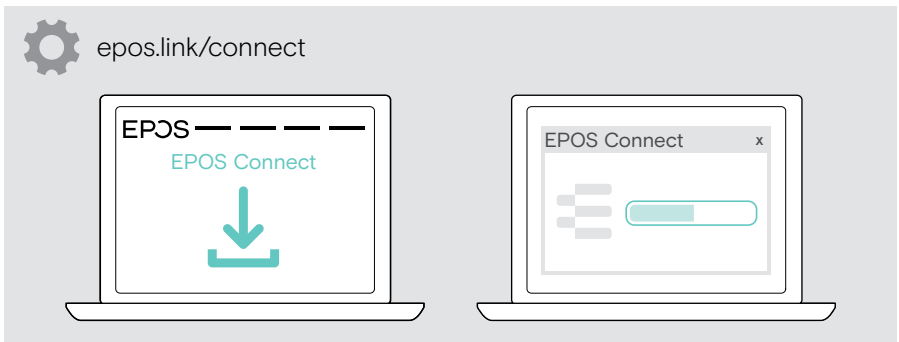

# How to use – the basics

## Adjusting the camera

You can adjust the angle of the camera physically. Activate the camera e.g. via your UC solution.

- 1 Loosen the affixing screw at the wall mount's bottom a bit.
- 2 Change the camera position:
  - A slide a little backwards or forwards or
  - B rotate to the left- or right-hand side or
  - C move a bit up and down.You will feel a slight resistance if you reach the maximum angle.
- 3 Tighten the screw again.

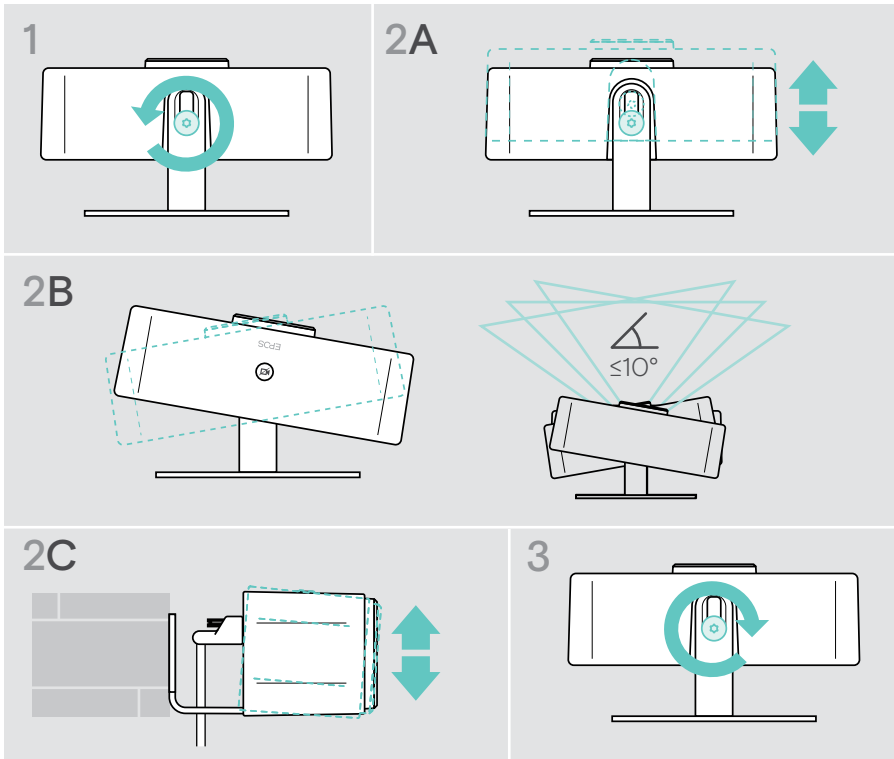

## Joining meetings / calls



### CAUTION

Risk of hearing damage!

Listening at high volume levels for long periods can lead to permanent hearing defects.

- > Do not continuously expose yourself to high volumes.

You can join meetings and calls via your UC solution (e.g. Zoom, Microsoft Teams).

- > Join your meeting or initiate a call via your UC solution.  
The camera gets active. The LED changes from dimmed to full white.

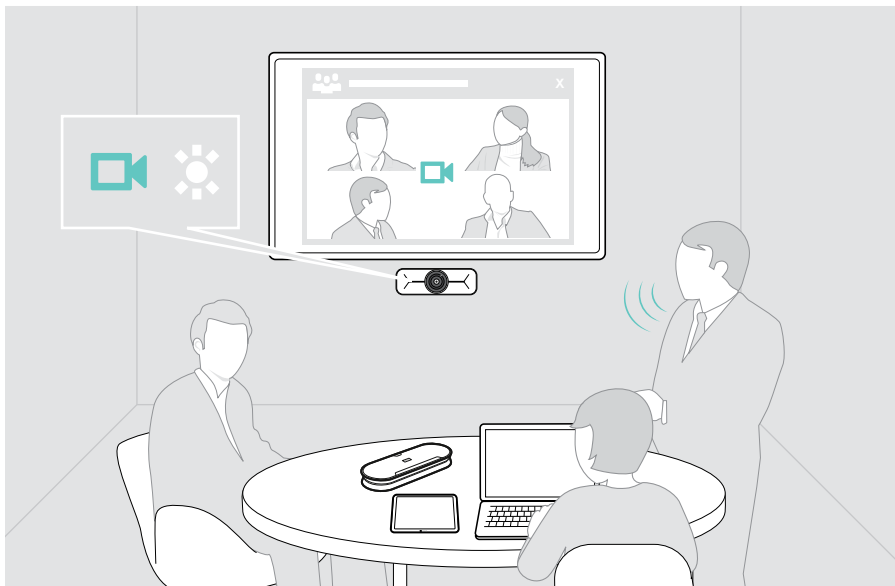

## Good to know

### Changing the camera's pick-up zone

---

- > Change the Field of view (FoV) via EPOS Connect to capture all the meeting participants. The maximum FoV is 95°. The setting may have been lock by your IT admin.

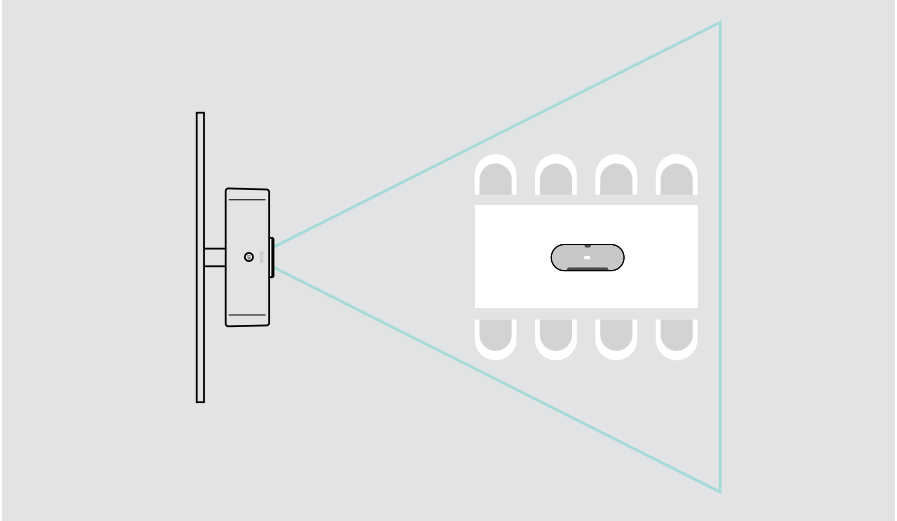

### Fine-tuning the camera's image

---

- > Change the camera's image via EPOS Connect. The setting may have been lock by your IT admin.

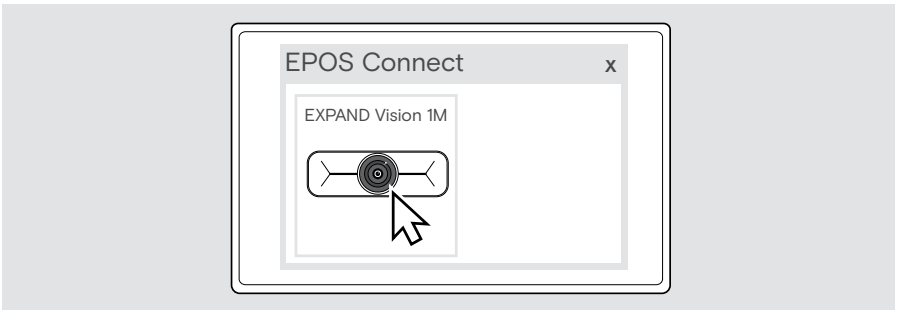

## Using the privacy shutter

For additional privacy, your EXPAND Vision 1M is equipped with a hardwired motorized button for disabling the camera.

- > Press the privacy button to open or close the privacy shutter.

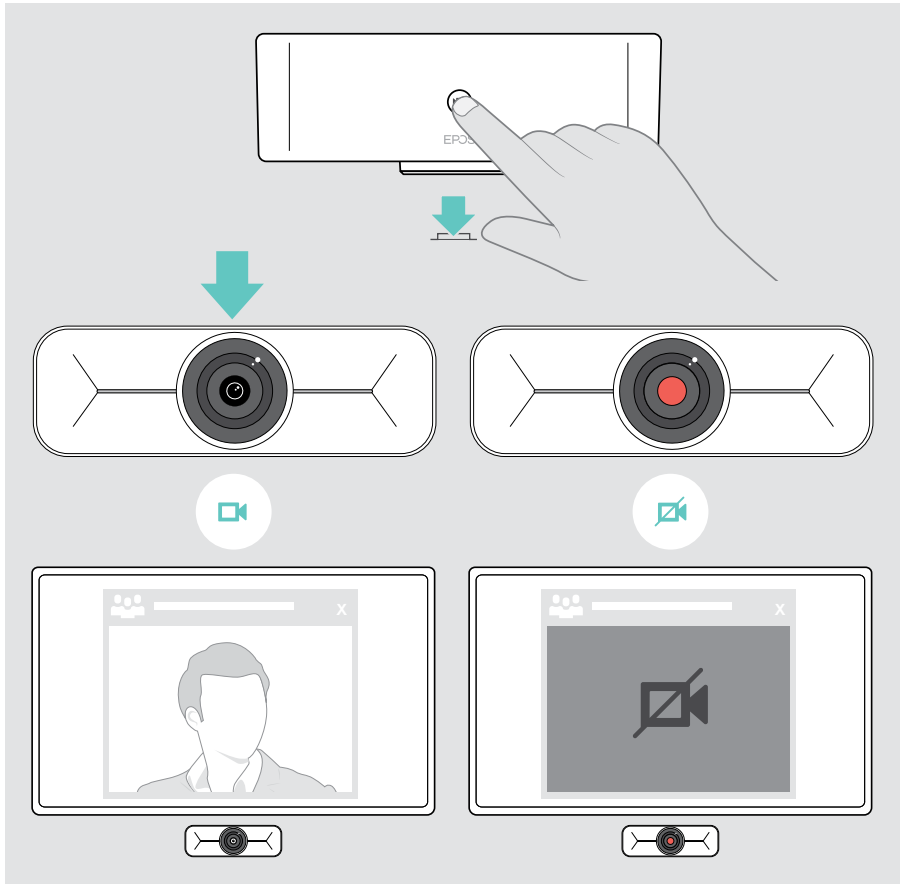

# How to care for your EXPAND Vision 1M

## Cleaning the product

---

### CAUTION

Liquids can damage the electronics of the product!

Liquids entering the housing of the device can cause a short circuit and damage the electronics.

- > Keep all liquids far away from the product.
  - > Do not use any cleansing agents or solvents.
- > Use a dry cloth to clean the product only.

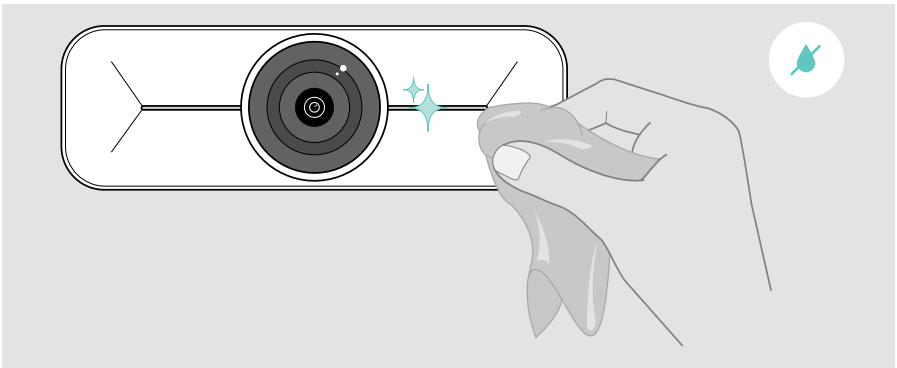

## Updating the firmware

---

- > Make sure, the camera is connected to your computer (see page 6).
- > Start EPOS Connect. If there is a new firmware available, the software will guide you through the update process.

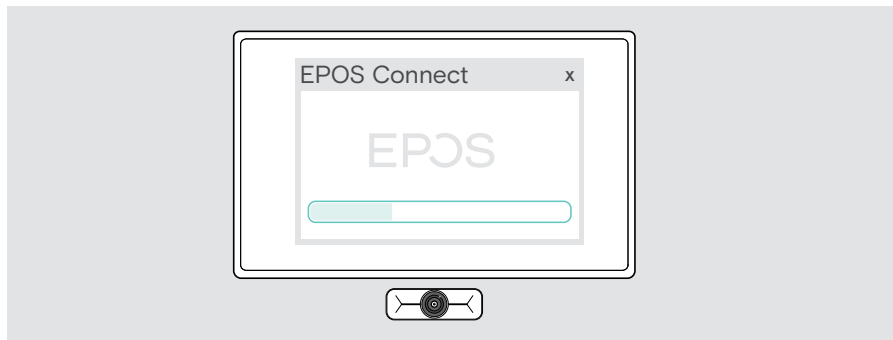

## If a problem occurs...

Problem	Possible cause	Solution	Page
Call can not be established	Firewall is blocking the call	> Check and change the network firewall settings.	-
Camera image not displayed correctly	Camera position not optimal	> Change the camera positioning and zoom level.	9
No picture or audio	Connectors not inserted correctly	> Check the cable connections.	6
	Microphones muted	> Unmute the microphones in your UC solution or your speakerphone.	-
	Privacy shutter in use	> Open the privacy shutter.	12
	Speakerphone is turned off	> Turn on the connected speakerphone.	
Low video or audio quality	Poor internet connection	> Check your internet connection performance.	-
	Plastic protection on lens not removed	> Remove the plastic protection.	-
Picture dark/light	Wrong settings	> Change the settings via EPOS Connect.	11

If a problem occurs that is not listed here or if the problem cannot be solved with the proposed solutions, please contact your local EPOS partner for assistance.

To find an EPOS partner in your country, search at [eposaudio.com](http://eposaudio.com).



# EPOS

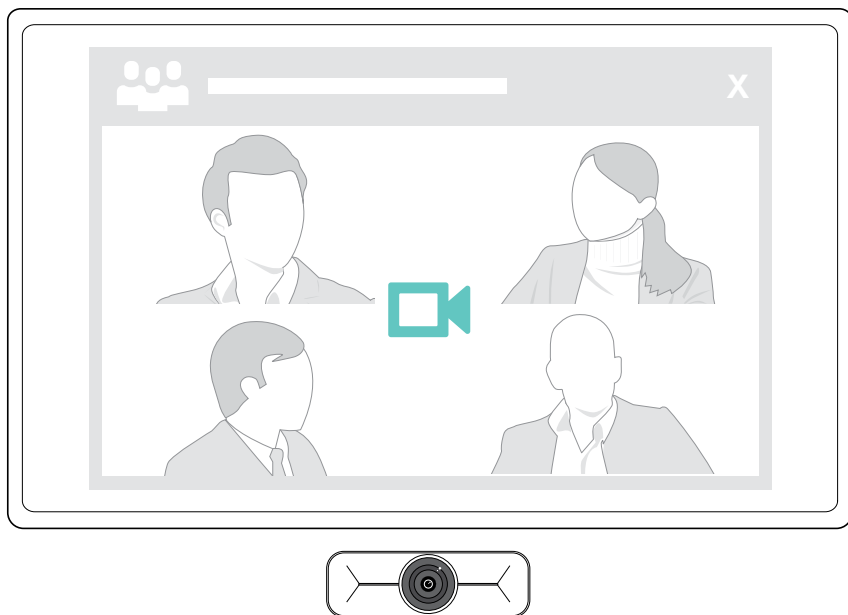

**DSEA A/S**

Kongebakken 9, DK-2765 Smørum, Denmark  
eposaudio.com

Publ. 01/23, A01